



# Card Gaming Tables

TCSJOHNHUXLEY's Card Tables represent the gold standard in live gaming furniture, combining traditional handcrafted excellence with the latest in operational technology. Designed for maximum versatility, our range serves as a high-performance foundation for any game—from the high-speed action of Blackjack to the strategic depth of Poker.



## Features & Benefits

- Various standard base styles and custom designs available
- Adjustable feet or fixed-floor bracketing
- Industry leading layouts provide unlimited colour and designs
- Removable insert, flip-top or standard tabletop options
- Leather or vinyl armrest, available in a wide range of colours
- Comprehensive choice of foot rails (brass or chrome), drink rails, holders, and ashtrays
- Options include "H" or "X"-style legs, barrel bases, or custom designs with optional LED edge-lit panels
- Foot-rail - brass or chrome
- Option to integrate with the Supernova Progressive Jackpot System and add LED bet sensors to the layout

## World Class Craftsmanship

As the world's leading manufacturer of live gaming equipment, TCSJOHNHUXLEY is known for bringing quality craftsmanship, combined with sophisticated technology to the table, with all our card tables featuring stand-out designs and eye-catching visuals. With over 50 years of experience, our gaming tables are recognised around the world for unquestionable quality, outstanding craftsmanship, and excellent finishes. Each table is manufactured by highly skilled craftsmen and can be built to your bespoke needs, with all the latest colours, finishes and materials available to compliment any casino brand, colour scheme or design.

## A Truly Custom Service

Whether your preference is for traditional or theme styling, our tables are the perfect choice for any card room or exclusive high limit/VIP gaming area. Available in a wide range of standard base designs including "H"-style or "X"-style legs, barrel base or bespoke designs, the TCSJOHNHUXLEY Card table also comes with a comprehensive choice of accessories including foot rails, drinks holders and armrest styles. Operators can choose from card table sizes for up to 7 players or Kidney shapes for up to 10 players, with further options for leather or vinyl armrests and brass or chrome footrails.

## Cutting Edge Technology

Alongside exquisite design sits the latest in cutting edge technology. From the integration of the dealer console and Ora Displays to embedded LED bet sensors, TCSJOHNHUXLEY seamlessly combines tradition with technological evolution providing operators with gaming tables that look stunning and deliver more.

## Ideal for the Supernova Jackpot System

Our card tables lend themselves perfectly to the Supernova Progressive Jackpot System, providing an ideal platform for high-impact gaming. Available for a wide range of games, operators can create multiple unique progressives and side-bets for any table game, monitor the success of them in real-time and, if necessary, modify the game configurations instantly (subject to local regulations).

### Product Specifications

#### Standard Blackjack Table

Table Height	990mm	38.98 in
Table Width	2251mm	88.62 in
Table Depth	1506mm	59.29 in
Table Shipping Weight	90kg	198.5 lbs

#### Standard Kidney Shape Poker Table

Table Width	2440mm	96.06in
Table Height	1220 mm	48.03in

Colour Options Available in a number of colours and finishes

LED Options LED edge lit panel built into the base or LED lighting strips incorporated into the base

Electronic Options Built-in cooling fans  
LED bet sensors  
Dealer Console

Compatible Products Ora Display range  
T-Connect  
Supernova  
A Plus Shuffler

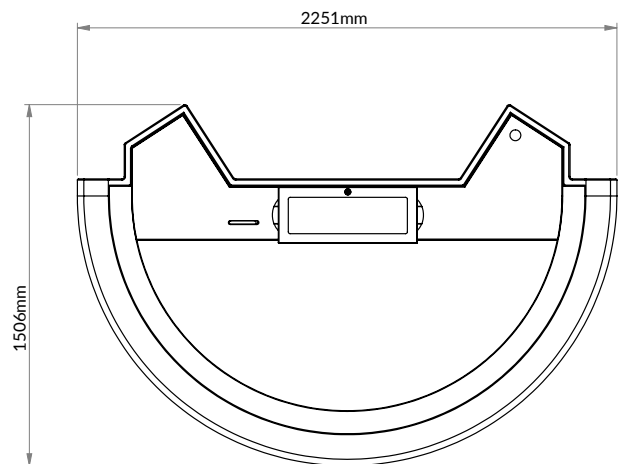
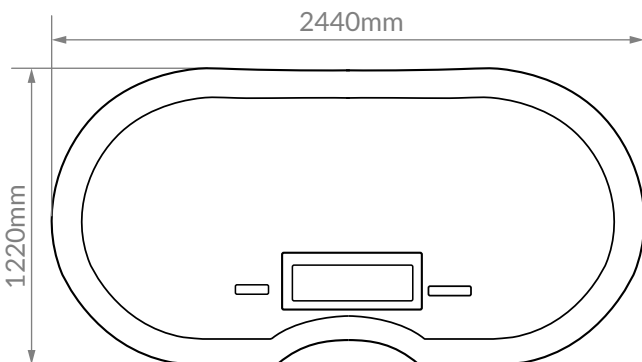

All sizes are based on popular table dimensions, TCSJOHNHUXLEY manufactures all tables in various sizes to meet your needs.